

## Huck Gun- 10224

The Huck 10224 is a lightweight high speed workhorse that is suited for both production and repair work. A rugged die cast aluminium body with internal wear resistant surfaces and high performance seals that require minimal maintenance. This should be your first choice when installing Hucks. The tool allows for the interchange of Huck fastener sizes or types, so you can install both 3/16 and 1/4 Huck rivets and Huck bolts with the simple change of a nose (additional extra).

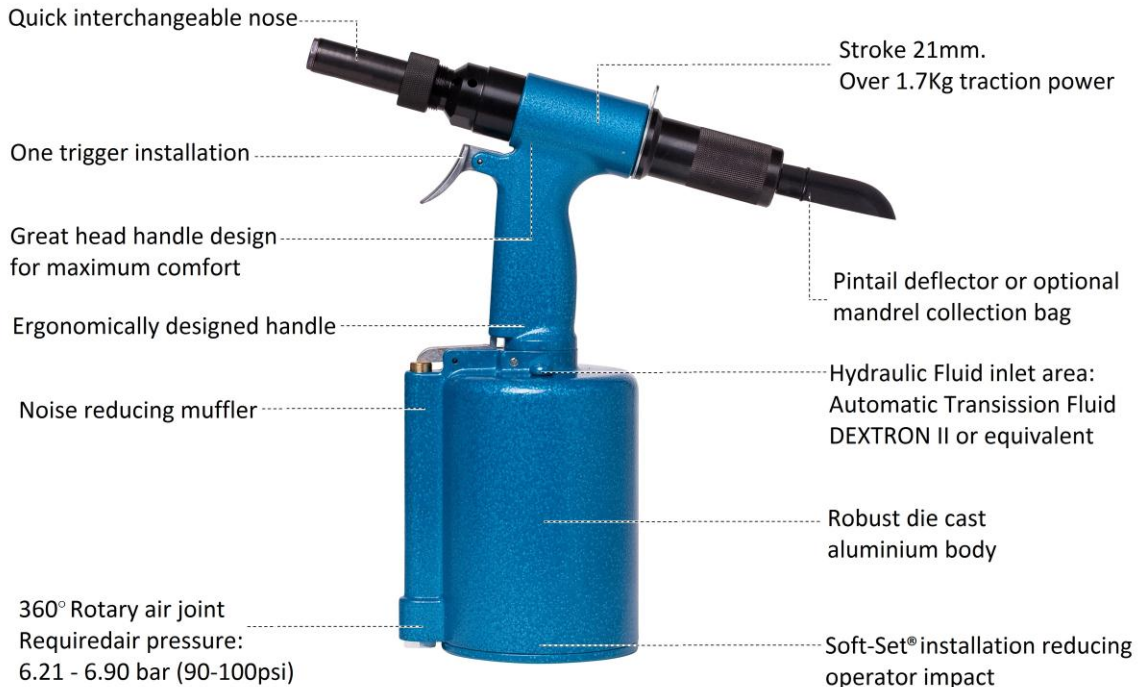

HG-10224 Specifications	
<b>Weight</b>	2.8 Kg
<b>Air Pressure</b>	6.21 -6.9 bar (90-100psi)
<b>Stroke</b>	21mm
<b>Air Consumption</b>	7CFM (210 l/min)
<b>Capacity</b>	19kN @ 6.21 bar (4271lbs @ 90psi)
<b>Nose Assembly</b>	Huck Bolt & Huck Rivet Nose 3/16 & 1/4

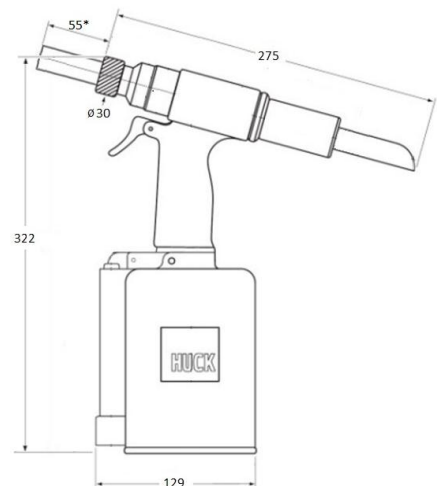

## **Preparation for use**

An air supply of 85-90 psi must be available (6, 3kp/cm<sup>2</sup>). Every attempt should be made to furnish 90 psi of clean dry air to the tool. Connect the tool to an air supply equipped with a filter, regulator and lubricator. If no lubricator is available, pour a small quantity of clean light machine oil into air inlet (43). Press tool trigger a few times and observe spindle retraction. Attach the nose assembly as shown on the applicable Nose Assembly Data Sheet.

## **Operation**

Place the pin in the prepared hole and the collar over the pin. Push the tool with attached nose assembly over the pintail until the tool nose touches the collar. Depress trigger and hold it until the pintail is separated and release the trigger. The nose will eject automatically. Blind Fasteners may be placed in the work hole or in the end of the nose assembly. In either case, the tool must be held firmly and at right angle to the work. Depress the trigger and repeat, if necessary, until the Fastener is installed and the pintail breaks off.

## **Maintenance**

Regular inspection and immediate repair of minor faults will maintain the tool and nose assembly at its highest operating efficiency and eliminates unnecessary breakdowns. Daily, before putting the tool into service, observe the following practice:

Always blow out the airline to clear it of all accumulated dirt or water before connecting air hose to tool. If the tool is in continuous use, remove the air hose and lubricate the tool with a few drops of light oil every two or three hours. Nose assemblies should be cleaned periodically. Check completeness according to the applicable Nose Assembly Data Sheet.

Caution: Do not use air pressure greater than 95 psi (7kp/cm<sup>2</sup>) as this will cause the O-Rings to become dislodged from their mountings.

Do not abuse the tool by dropping it, using it as a hammer or otherwise causing unnecessary wear and tear.

## Disassembly and assembly

1. Disconnect air hose and remove nose assembly.
2. Unscrew cylinder cap (51) with wrench.
3. Pull out air piston (58) in a straight line with suitable pliers.
4. Remove adapter (4)
5. Unscrew rear gland (21), remove spring (18) and push out pull piston (15).
6. Push out slotted pin (22 & 47) and remove trigger linkage.
7. Unscrew air inlet (41) and remove seat (40) and throttle valve assembly.
8. Push out slotted pin (46), unscrew lock nut (48) with 32mm socket, and separate handle (1) from cylinder (45).

Before assembling, inspect all parts and replace if necessary. Clean all parts thoroughly with mineral spirits and lubricate with Lubriplate No. 1300AA (Huck Part Number: 502723). A good practice to follow is to replace all O-Rings when the tool is disassembled for any reason. Then assemble, taking care not to damage O-Rings, handle and cylinder housing.

## Filling the tool

1. With cylinder cap (51) and air hydraulic piston removed, invert the tool and fill with filler bottle (Huck Part Number: 100932) with automatic transmission fluid until it levels O-Ring (31).
2. Insert piston assembly and push it all the way ten times.
3. Carefully push on the air piston until solid back pressure is noted. Measure the distance between bottom cylinder (45) and air piston (58), which should be approximately 20mm (see illustration figure 1.) If necessary, add or remove fluid.
4. Install and tighten cylinder cap (51) with wrench.

<b>TROUBLE SHOOTING</b>		
<b>TOOL MALFUNCTION</b>	<b>PROBABLE CAUSE</b>	<b>CORRECTIVE ACTION</b>
1. Tool fails to operate when trigger is depressed	Incomplete or defect throttle valve assembly	Check and replace defective parts, O-Rings.
2. Tool will not break pintail of fastener	Nose Assembly not complete. Air supply pressure low.	Check with applicable Nose Assembly Data Sheet. Set to 85-90 psi (6 kp/cm <sup>2</sup> )
3. Short stroke, less than 22mm	Check oil levels	Refill per instructions.
4. Hydraulic fluid exhausting with air	Worn O-Rings.	Replace O-Rings (31 & 32)
5. Leakage at rear pull piston gland.	Worn O-Rings.	Replace O-Rings (17 & 16)
6. Leakage at front pull piston	Worn O-Rings.	Replace O-Rings (7 & 8)
7. Pull piston will not return	Broken spring	Replace spring (18)

# HG-10224: Exploded View

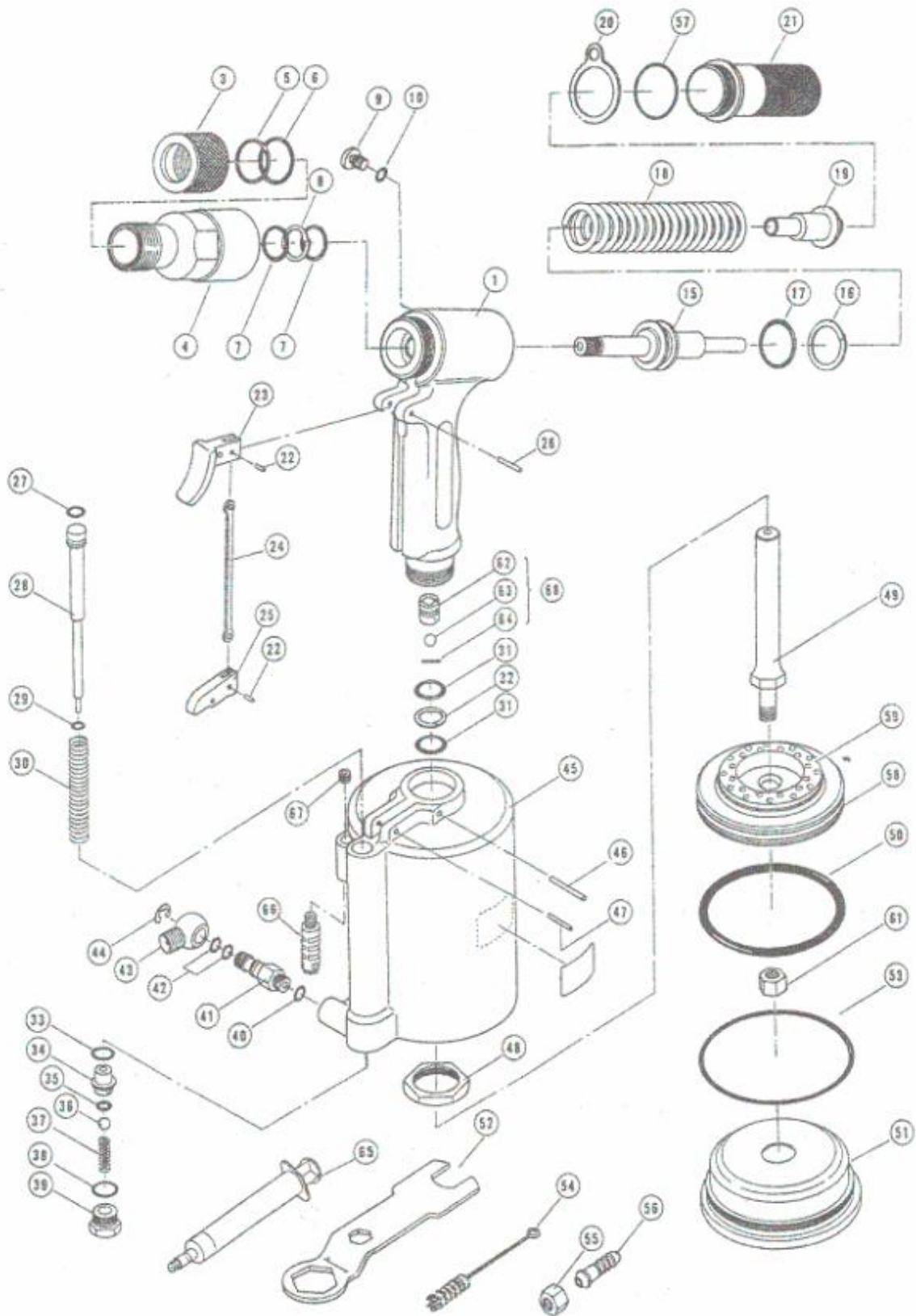

## HG-10224: Parts List

REF. NO	PART NO.	DESCRIPTION	REF. NO.	PART NO.	DESCRIPTION
1	LH-401	Handle	39	LH-413	Plug
	INCL.	7(2),8,9,10,31(2),32,62,63,64	40	LH-77	O-Ring S-10
3	103090NR	Nut-Retaining	41	LH-414	Nipple
4	LH-195	Adapter-Anvil	42	LH-78	O-Ring P-7
5	103087NR	Washer-Stop	43	LH-415	Connector
6	LH-58	O-Ring P-20	44	LH-416	Retaining Ring
7	LH-281	O-Ring P-15	45	LH-417	Cylinder
8	LH-282	Backup Ring P-15	46	LH-59	Pin 4 x 31
9	104293NR	Bleed plug	47	LH-58	Pin 3 x 18
10	LH-70	O-Ring P-5	48	LH-423	Lock Nut
15	LH-402	Pull Piston	49	LH-418	Piston Rod
	INCL.	16, 17		INCL.	61
16	LH-21-1	Backup Ring P-24	50	LH-79	O-Ring P-85
17	LH-21	O-Ring P-24	51	LH-419	Cylinder Cap
18	LH-403	Spring		INCL.	53
19	LH-404	Guide Tube	52	LH-455	Wrench
20	LH-15	Hanger	43	LH-81	O-Ring G-95
21	LH-405	Rear Gland	54	LH-80	Brush
22	LH-32	Pin 3 x 6	55	LH-420	Nut ¼
23	LH-406	Trigger	56	LH-422	Hose Connector ¼
24	LH-33	Linkage	57	LH-50	O-Ring S-28
25	LH-407	Lever-Throttle	58	LH-421	Air Piston
26	LH-57	Pin 3 x 22		INCL.	50, 59
27	LH-71	O-Ring P-9	59	LH-28	Bumper
28	LH-408	Valve-Throttle			
29	LH-75	O-Ring P-5	61	LH-54	Nut
30	LH-409	Spring	62	LH-456	Shock less Plug
31	LH-426	O-Ring P-12.5	63	LH-457	Ball 06
32	LH-427	Backup Ring P-12.5	64	LH-458	Pin 2 x 10
33	LH-74	O-Ring P-10	65	LH-459	Priming Pump
34	LH-410	Sleeve	66	LH-460	Silencer
35	LH-75	O-Ring P-5	67	LH-461	Plug
36	LH-411	Ball 08	68	LH-462	Shock Absorber
37	LH-412	Spring		INCL.	62, 63, 64
38	LH-76	O-Ring S-14	Not shown	100378	Pintail Deflector